

REVISIONS

REV.	DESCRIPTION	DATE	SIGNATURE
A		2024-04-11	PB

THIS DOCUMENT MUST NOT BE COPIED WITHOUT
 OUR WRITTEN PERMISSION, AND THE CONTENTS
 THEREOF MUST NOT BE IMPARTED TO A THIRD
 PARTY, NOR BE USED FOR ANY UNAUTHORISED
 PURPOSE. CONTRAVENTION WILL BE PROSECUTED.

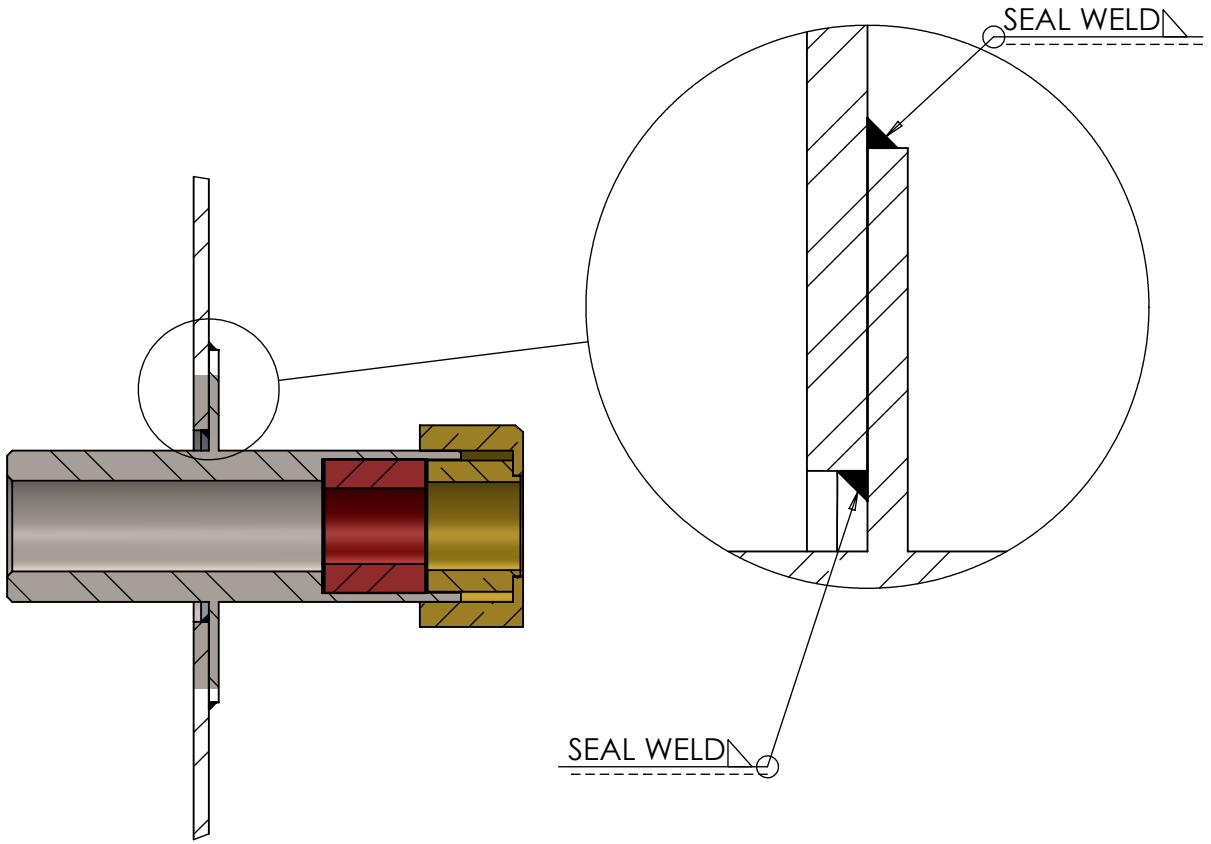

1. Remove Electroplating from edges of flange and threaded area where weld will be applied.
2. Center and position the DB Gland Flat to the plate.
3. Tack weld on the front side of the flange in four positions.
4. Continue welding around the flange until complete.
5. Complete a full seal weld on rear side of opening.

Ritad Drawn	Kontr. Check	Granskad Reviewed	Godkänd Approv.	Tolerans där ej annat anges Tolerance unless otherwise not stated.	Smst. nr. Assembly drawing no.	Ersätter Replaces	E
PB	PB	OF	ML	Ytjämnhet där ej annat anges. Surface finish otherwise not stated.	Material	Ersatt av Replaced of	Vikt Weight
240320	240411	240412	240412			Alla mått och uppgifter avser färdig produkt om ej annat anges All measures and other information refer to finished products unless otherwise not stated.	
				INSTALLATION DRAWING FOR WELDED DB GLAND		Kund ordernr. Customer order no	
						Ritn. nr. Draw. no.	Rev.
						1240122	A